

Fresa para rasgos de chaveta, corte no diâmetro, dente fresado.
 Fresa para ranhuras, diente fresado.
 Slotting cutter, relief tooth.

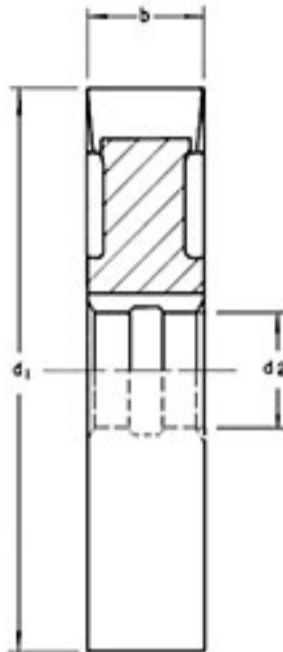

1252
 dente reto
 diente recto
 straight tooth

HSS (M2)

d1 js 16 mm	b k 8 mm	d2 H7 mm
50	4	16
	5	
	6	
	8	
	10	
63	6	22
	8	
	10	
	12	
	14	
80	8	27
	10	
	12	
	14	
	16	
100	10	32
	12	
	14	
	16	
	18	
	20	
	22	
	25	

Ex. de especificação: 1252 - 63 x 8 x 22

Fresa acoplada para rasgo de chaveta com espessura ajustável.
 Fresa acoplada e ajustable para ranhuras.
 Interlocking and adjustable slotting cutter.

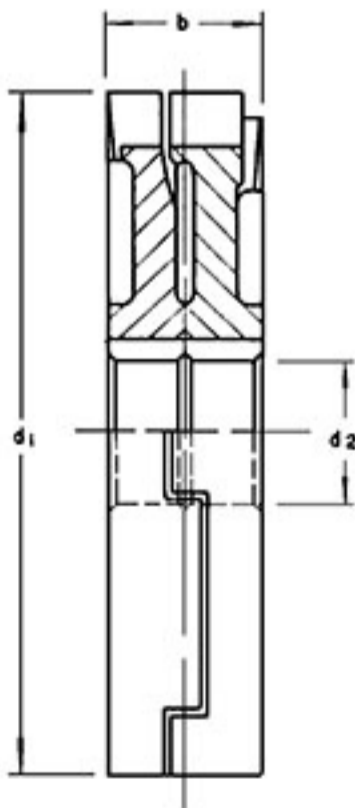

1266
 DIN 1891 tipo N
 dentes cruzados
 dientes cruzados
 staggered teeth

HSS (M2)

d1 js 16 mm	k11 mm	b Ajustável até mm	d2 H7 mm
63	12	13	22
	14	15.5	
	16	18	
	18	20	
	18	20	
80	14	15.5	27
	16	18	
	18	20	
	20	22.5	
	20	22.5	
100	16	18	32
	18	20	
	20	22.5	
	22	25	
	25	28.5	
125	18	20	32
	20	22.5	
	22	25	
	25	28.5	
	28	31.5	
160	20	22.5	40
	22	25	
	25	28.5	
	28	31.5	
	32	36	
200	20	22.5	40
	22	25	
	25	28.5	
	28	31.5	
	32	36	

Ex. de especificação: 1266 - 63 x 12 x 22