

Fresa angular com haste cilíndrica, corte à direita.  
 Fresa en ángulo con vástago cilíndrico, corte a la derecha.  
 Straight shank single angle milling cutter, right-hand cut.

HSS (M2)

$\sigma$	d 1 js 16 mm	b mm	l mm	d 2 h8 mm
45°	16	4	60	12
45°	20	5	63	12
45°	25	6,3	67	12
45°	32	8	71	16
60°	16	6,3	60	12
60°	20	8	63	12
60°	25	10	67	12
60°	32	12,5	71	16
70°	16	7	60	12
70°	20	9	63	12
70°	25	11	67	12

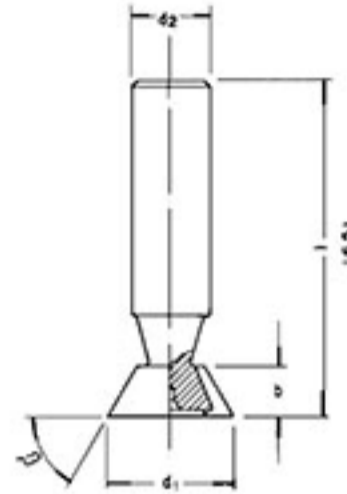

**1651**

DIN 1833 A - H  
 Dove tail

p/ rasgo "rabo de andorinha"  
 corte na lateral e no topo  
*corte lateral y frontal*  
 side and face cutting

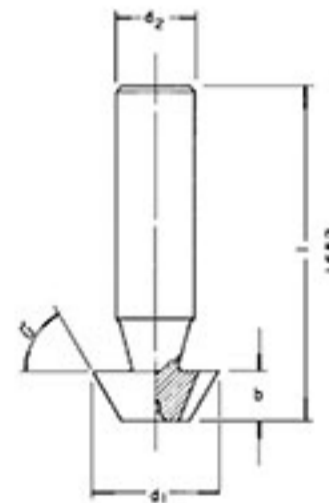

**1652**

DIN 1833 B - H  
 corte somente na lateral  
*corte solamente en la lateral*  
 side cutting only

Ex. de especificação: 1651 - 45° x 16