

EUROBOOR

FOR PROFESSIONALS BY PROFESSIONALS

USER MANUAL

TO REDUCE THE RISK OF INJURY USER MUST READ AND UNDERSTAND INSTRUCTION MANUAL



ECO.50

Magnetic Drilling Machine

SERIAL NO. _____ DATE OF PURCHASE _____

1 - Table of Contents

1	Table of Contents	page 1
2	Safety	page 2
	Before Use	page 3
3	Items Included in Delivery	page 4
4	The Hole Cutter	
	Hole Cutter Selection	page 5
	Cooling/Lubrication	page 6
4	Tool Assembly	
	Morse Taper Assembly	page 6
	Hole Cutter Assembly	page 6
	Drill Chuck Assembly	page 7
	Installation of 13mm Chuck by using Adaptor IBK.14	page 7
	Installation of 13mm Chuck directly on the motor unit	page 7
4	The Magnetic Drilling Machine	
	The Magnetic Base	page 7
	The Control Panel	page 8
	Drilling	page 9
5	Maintenance	page 10
6	Spareparts & Exploded View.....	page 11



Read these directions and safety instructions completely and attentively and carefully follow these recommendations. All safety measures must be observed at all times when using magnetic drilling machines. Improper use and carelessness increase the risk of accidents. This is for your own safety. Should you have any doubts about the use of this machine,



please contact your supplier

2 - Safety

1. During any work on non-horizontal components, the machine must always be secured with the supplied safety chain.
2. The magnetic drilling machine may only be used on a flat and clean foundation.
3. If the machine or the lead show signs of damage, the magnetic drilling machine must be switched off immediately.
4. Wearing safety glasses, hearing protection and protective clothing is necessary.
5. Do not wear any loose clothing or jewellery that may get entangled in the moving parts of the magnetic drilling machine.
6. Use only accessories or parts that are recommended by Euroboor.
7. During drill operations, the hole cutter must be cooled and lubricated with good quality cutting or lubrication oil.
8. The motor must be switched off when tightening the machine with the safety chain.
9. When changing a hole cutter, the magnetic drilling machine must be disconnected from power supply.
10. Clean the area around the machine regularly. Keep the bottom of the magnet and keep it clean and dry.
11. Regularly inspect whether all screws, nuts and bolts are tight.
12. Remove the burr or slug from the hole cutter after each hole. Caution, the part may be hot!
13. Before using the machine make sure it is connected to the correct voltage and that all grips and parts are tightly attached.
14. When using the drill on non-horizontal surfaces, you must use a drilling compound or cutting paste.
15. Do not use oil because the oil can drip into the motor unit.



When using this machine, you MUST wear ear and eye protection. Euroboor has included these articles as standard accessories for your own safety. Do NOT touch the drill when it is running. Always follow the recommendations for personal protection when using this tool.



Before use

Euroboor magnet drilling machines are specially designed for drilling holes in steel, possibly expanded by the possibility of tapping/reaming/countersinking (depending on model). Euroboor magnetic drilling machines may not be adapted and/or used for applications other than those they were designed for, including driving other machines.

Make sure that you can oversee the entire work areas from where you are operating this machine. Use barriers to keep others away. Do not use the machine in places subject to hazard of explosion- electrical tools produce sparks which may ignite flammable materials or gasses. To prevent electrical shocks, do not use the machine in moist or wet conditions or environments. Always operate this tool using both hands. Make sure the work piece is always clamped down safely.

This magnetic drilling machine is equipped with a lead and plug approved for the country or region it is to be used in. The yellow-green wire in the lead is the earth wire. Never connect this to a pole under voltage. All Euroboor magnetic drilling machines are manufactured to use with AC current and not suitable to work on DC current. Make sure the magnetic drilling machine is connected to a stable power supply. Euroboor does not recommend the use of a generator or other mobile power supply for power supply. Euroboor does not recommend the use of extension cables. If there is no other way, use good quality cables and keep extension cables as short as possible. Be aware that long power leads can cause less current.

3 - Items Included in Delivery

Magnetic Drilling Machine	YES	Pilot Pin	NO
Carrying Case	YES	Morse Taper	YES
Drill Chuck 13mm	NO	Morse Taper Ejector Pin	YES
Tap Collets M10-M12-M14-M16	NO	Manual	YES
Allen Key 2.5	YES	Safety Chain	YES
Allen Key 3	NO	Drilling Oil	YES
Allen Key 4	YES	Safety Ear Protection	YES
Allen Key 5	YES	Safety Glasses	YES
Wrench 8	YES	Safety Gloves	YES

4 - The Hole Cutter

Hole Cutter selection

There are many different types of steel. It is not possible to drill all these types of steel with 1 type of cutter. Euroboor recommended the following :

Euroboor+ HSS Series For drilling holes in general 37/52 steel and aluminium

HCS	12 mm - 130 mm	Hole cutters with cutting depth 30 mm	increasing by 1 mm
HCL	12 mm - 130 mm	Hole cutters with cutting depth 55 mm	increasing by 1 mm
HCY	20 mm - 50 mm	Hole cutters with cutting depth 75 mm	increasing by 1 mm
HCX	20 mm - 50 mm	Hole cutters with cutting depth 100 mm	increasing by 1 mm

Also available in inch sizes:

HCS	7/16" - 5"	Hole cutters with cutting depth 30 mm	increasing by 1/16"
HCL	7/16" - 5"	Hole cutters with cutting depth 55 mm	increasing by 1/16"
HCY	3/4" - 2 1/16"	Hole cutters with cutting depth 75 mm	increasing by 1/16"
HCX	3/4" - 2 1/16"	Hole cutters with cutting depth 100 mm	increasing by 1/16"

Euroboor Cobalt Series For processing steel, stainless steel and other high-quality steel alloy types

IBS	12 mm - 130 mm	Hole cutters with cutting depth 30 mm	increasing by 1 mm
IBL	13 mm - 130 mm	Hole cutters with cutting depth 55 mm	increasing by 1 mm

Euroboor TCT Series Tungsten Carbide Tipped. Cutters with hard metal teeth

HMS	14 mm - 50 mm	Hole cutters with cutting depth 35 mm	increasing by 1 mm
HML	14 mm - 130 mm	Hole cutters with cutting depth 50 mm	increasing by 1 mm

Euroboor TRC Series With hard metal teeth, For drilling holes in rails

TRCS.190	19 mm	Hole cutter with cutting depth 35 mm
TRCS.300	30 mm	Hole cutter with cutting depth 35 mm
TRCS.330	33 mm	Hole cutter with cutting depth 35 mm

NOTE : Hole cutters 12mm - 60mm have a 19,05 mm Weldon shank
 Hole cutters 61mm - 130mm have a 31,75 mm Weldon shank

Cooling/Lubrication

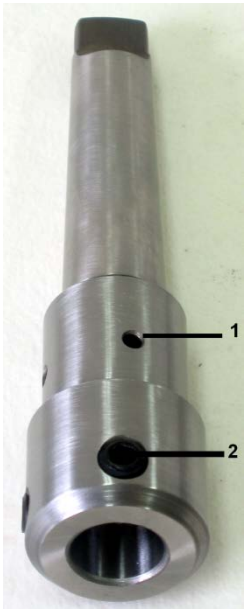

- 1 Holes for cooling and lubrication oil
- 2 Fixing screws of Morse Conus

Euroboor recommends the use of cooling and lubrication agents. Not only do these assist in drilling but they will also lengthen the lifespan of your tools. One of the advantages of the use of hole cutters is that cooling and lubrication agent can be supplied from the inside, so that the agents end up in the right place.

All magnetic drilling machines from Euroboor can be equipped with a automatic cooling system which provides a guaranteed supply of the cooling and lubrication agents from the inside. If your machine is not be equipped with an automatic coolant system it will still be possible to cool from the inside.

Use the holes in the morse conus (number 1 in picture) for this purpose by squirting the cooling and lubrication agent through them and fill the morse conus.

NOTE : For vertical or upside-down processing, Euroboor recommends the use of a drilling compound or paste like IBP50/2.

4 - Tool Assembly

Morse Taper Assembly

Mount the Morse Taper into your machine by push it firm into the shaft extending from the motorunit. Beware that the tip on top of the Morse Conus is in line with the shaft. To take the Morse Conus out use the Ejector Pin to force it out.

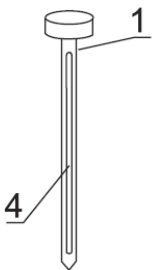

Hole Cutter Assembly

- 1 : Pilot Pin
- 2 : Center hole in shank of Hole Cutter
- 3 : Shank of Hole Cutter
- 4 : Groove or flatted surface for oil pass
- 5 : Flat surface for fixing Hole Cutter

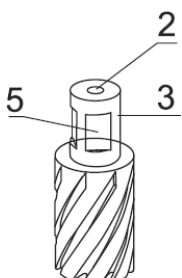

Clean the inner wall and the shaft of the Hole Cutter to ensure proper oil supply. First insert the Pilot Pin into the center hole of the Shank. After that you can slide the Hole Cutter assembly into the spindle or morse conus of your Magnetic Drilling Machine. After sliding the Hole Cutter Assembly into the morse conus, make sure the two flat surfaces (number 5 in picture) are located exactly in front of the two

fixing screws of your spindle (see number 2 in picture of cooling/lubrication. Tighten them both subsequently with the included 5mm Allen Key.

Drill Chuck Assembly

The option of making our machines suitable for the use of standard spiral drills and other tools by using a cylindrical shaft is an important characteristic of Euroboor magnetic drilling machines. Please see the technical data for maximum capacity.

Installation of 13mm Chuck by using adapter IBK.14

The IBK.14 is a adaptor from 1/2"x20 UNF to 3/4" Weldon.

Attach a Drill Chuck (like Euroboor IBK.13) with internal 1/2"x20 UNF on the IBK.14 adaptor.

To attach the assembly into your Spindle, follow the instructions (with exception of the Pilot Pin) for installation of a Hole Cutter. Adaptor IBK.14 can be used on most machines in our program.

Installation of 13mm Chuck directly on the motor unit

For the ECO.50 and ECO.50T magnetic drilling machines it is possible to install a drill Chuck directly to the shaft extending from the motor unit. Attach to the drill chuck with article number IBK.13-B16 a adaptor with article number B16-MC2. This way the drill chuck can be mounted as a Morse Conus in your machine.

4 - The Magnetic Drilling Machine

The Magnetic base

Material of minimum 10mm thickness is required for the magnet to work the best.

The attachment force generated by the magnet depends on various factors.

- Thickness of the material the magnet is placed on
- Paint or coating of the material the magnet is placed on.
- Metal chips, oil or other dirt under the magnet.

If the LED indicator lights up GREEN, the magnet is generating sufficient attachment force. If the LED indicator lights up RED, the magnet may not generating sufficient attachment force.

We would like to point out that this is only an indication and not a certainty that the magnet will not release from the material. Euroboor accepts no liability ensuring from the magnet indicator not functioning or functioning poorly.

Make sure that the magnet attaches tightly to the work piece before turning on the motor unit of the magnetic drilling machine. Euroboor magnets have 2 coils; make sure that both coils are in contact with the material. Do not connect any other machines to the electrical outlet the magnetic drilling machine is plugged into, as it may result in the loss of magnetic force. Always use the safety chain included. Drilling above your head is extremely dangerous and is not recommended. For the use of magnetic drilling

machines on pipes, not-flat or non-magnetic materials, we refer to our brochure or our website www.euroboor.com where several vacuum tightening systems and pipe clamping systems are mentioned.

The Control Panel

The control panel on your magnetic drilling machine is designed for maximum operating facility and safety.

1 - The Magnet Switch:

This switch is used to switch the main power and also the magnet On and Off. This switch is included on every Euroboor magnetic drilling machine

2 - The On/Off Switch:

This switch is used to switch the motor unit On and Off and is included on every Euroboor Magnetic Drilling Machine

3 - The Fuse holder with Fuse:

This Fuse holder is included on every Euroboor Magnetic Drilling Machine and holds the fuse type : 5x20, F2A.

4 - The Magnet LED Indicator:

This LED indicator shows the generated magnetic force.



Drilling

Now that you have read the explanatory information and safety recommendations above, you are ready to actually start drilling. Follow these 10 steps for best drilling result :

- 1 Use the tip of the pilot pin to determine the center of the hole to be drilled.
- 2 Turn the magnet on and verify that the drill is in the right position and that the machine is pushed tight against the work piece.`
- 3 If your machine is equipped with a auto coolant system, put open the valve to release the oil. If your machine does not have a auto coolant system, fill the holes of the spindle with oil.
- 4 Turn the motor on at the highest setting and allow it to run at full speed.
- 5 Turn the arms to start drilling. Apply only a slight pressure when the hole cutter touch the metal. Do not push the hole cutter with force into the metal.
- 6 Apply a regular pressure while drilling. The drilling performance does not improve by putting more pressure on the tool. Too much pressure will overload the motor and your hole cutter will be worn sooner. ***Let the cutter do the job and give it time to cut the metal !!!***
- 7 Adjust the oil supply when necessary, if your drill does not have a auto coolant system, stop drilling regularly, refill the holes of the spindle and continue drilling.
- 8 Apply less pressure when the drill cuts through the material.
- 9 Turn the arms to put the motor in highest position and turn off the motor unit.
- 10 Remove the burr, metal chips and clean the cutter and surface without getting injuries.
Caution : The metal piece drilled out can be sharp and very hot!!

The ECO.50 have a 2speed gearbox. Easy said can the upper (high) gear be used for hole cutters till 20mm and twist drills. The lower gear is used for hole cutters above 20mm. Of course this is a general indication, at specific constructions and/or materials or used cutters can a lower or higher rpm give better results.

To select other gear, turn off motorunit and main power. Push the black switch on the side of the gearbox and slide to other position. A slight turn of the output shaft by hand while sliding the black switch to the other position can be necessary to line up the gears inside. Proof that the gear is locked if the black switch comes back to front.

!!! IMPORTANT !!!

**When using your magnetic drilling machine non-horizontal or upside-down be aware that no oil, drilling compound or metal chips can fall into the motor unit.
Euroboor accepts no responsibility for damage done to your machine
by such action under coverage of the warranty.**

5 - Maintenance

Just as every magnetic drilling machine with moving parts, your Euroboor magnetic drilling machine also needs regular maintenance service. A few recommendations follow :

- Clean all dirt, dust, metal chips and burrs of your magnetic drilling machine
- Regularly check the carbon brushes for wear
- Replace any defective parts immediately. This prevents properly function parts from being damaged.
- Adjust your guide regularly and make sure it is clean and greased. This prevents any movement from being created and the spindle, triangular guide (steady) and guide parts from excessive wear or damage. The guide can be adjusted by loosening the setting nut (#7 on spare part drawing) with included wrench 8, tightening the setting screws (#5 on spare part drawing) with included Allen key 2.5 and tightening the setting nut (#7) again with included wrench 8. The adjustment is done well when the motor unit can be turned to every possible position without falling down by its own weight.
- Check the grease in the gearbox regularly and replace it if necessary. We recommend you to store your machine on its side regularly so that the gear box grease can run back to where the gears are. This is very important when you have used your machine non-horizontal or upside down. Repair, modification and inspection of Euroboor Magnetic drilling machines must be done by a Euroboor authorized dealer. The parts list will be helpful if presented with the machine to the Euroboor dealer for service when requesting repair or other maintenance. Euroboor machines are constantly being improved and modified to incorporate the latest technological advancements. Accordingly, some parts (ie part numbers and/or design) may be changed without prior notice. Also, due to Euroboor's continuing program of research and development, the specifications of machines are subject to change without prior notice.

6 - Spare parts & Exploded view of ECO.50

1	020.0056	Frame	37	050.0587	Screw PKVZ4,8x35
2	020.0106	Screw SSM6x16	51	032.0156	Screw 3,9x60
3	020.0111	Washer M6	52	050.0182	Adaptor ring 22x0,2
4	020.0096	Setting Nut	53	050.0161	Needle bearing
5	020.0091	Setting Screw	54	032.0221	Bearing 8x22x7
6	050.0611	Magnet Hi/Lo	55	032.0171	Bearing 12x28x8
7	020.0201	Sensor	56	050.0251	First gear
8	050.0011	Slide	57	050.0231	Axle
9	032.0016	Rack	58	050.0246	Gear shaft
10	020.0156	Screw SSM6x20	59	050.0191	Spindle drive shaft
11	050.0141	Motorholder	60	050.0371	Carbon brush holder
12	020.0146	Screw SSM6x25	61	050.0147	Carbon brush set
13	040.0041	Top fixing plate 110mm	62	050.0112	Screw 4,8x45
14	020.0086	Brass rail set (stick)	63	032.0106	Screw 4,8x50
15	020.0084/4	Pressing strip 4 holes	64	050.0116	Adaptor ring rubber 22x2,5
16	020.0061	Capstan hub assembly	65	050.0466	Bearing 20x37x9
17	020.0077	End plate	66	050.0221	Bearing 17x40x12
18	020.0081	End screw	67	050.0177	Spindle gear
19	020.0066	Arm for Capstan	68	050.0171	Gear 34/40
20	020.0046	Motorcable	69	050.0261	Baffle
21	020.0041	Coupling nut for motorcable	70	050.0181	Armature 220v
22	020.0031	Coupling nut for maincable		050.0186	Armature 110v
23	020.0036	Main Cable	71	050.0276	Field 220v
24	020.0182	Screw+washer+nut		050.0277	Field 110v
25	PP.RSEU	Rear plate	72	050.0111	End cover
26	020.0101	Panel screw M4x8	73	050.0142	Housing
27	PP.50EU	Front plate	74	050.0176	Circlip 471/10
28	020.0206	Sensor LED+cable	75	050.0426	Circlip 471/15
29	020.0006	On/Off switch	76	050.0166	Circlip 472/28
30	020.0016	Fuse holder	77	050.0236	Inner gear plate
31	020.0017	Fuse F2A	77.1	050.0207	Gasket
32	020.0011	Magnet switch	78	050.0206	Gear casing
33	020.0001	Control Unit 220v	79	050.0431	Key for spindle
	020.0002	Control Unit 110v	80	050.0301	Key
34	020.0037	Cable clamp	81	032.0211	Casing pin
35	050.0101	Motorunit 220v	82	050.0291	Clutch shaft
	050.0102	Motorunit 110v	83	040.0286	Gear switch
36	050.0586	Cable housing	84	050.0211	Plate for gear casing

ECO 50

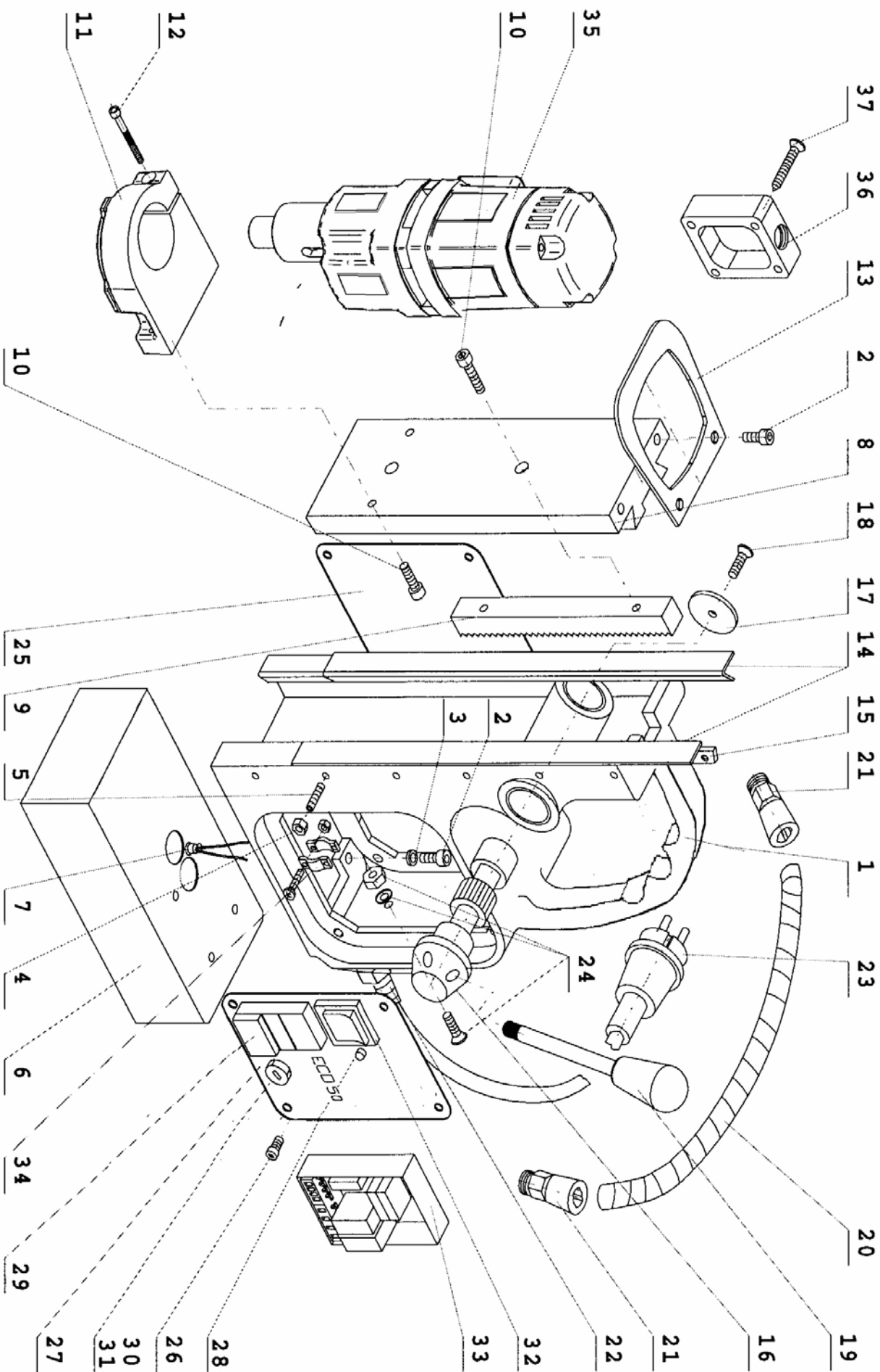

ECO 50

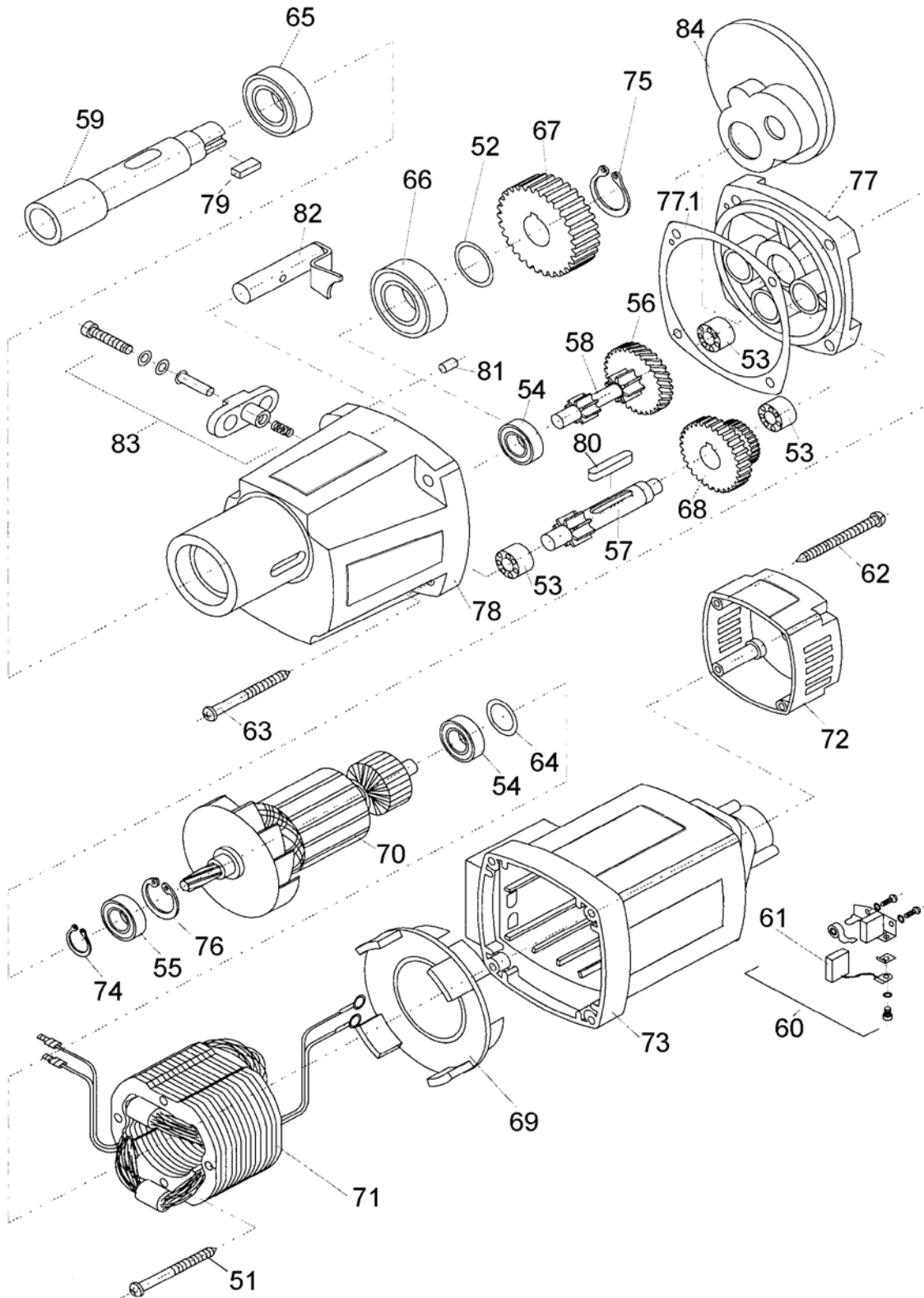

Important notice :

Because of minor changes to our machines it is recommended to provide the framenumber of your machine when ordering spareparts. This number can be found on front of machine at magnetic base and frame. When you have any doubt when ordering spareparts, please contact your supplier before ordering.