

Fresas para cremalheiras / eixos sem-fim, ângulo de pressão 20° perfil de referência I DIN 3972, forma A: com perfil reto; forma B: com perfil inclinado em 10°.

Rack milling cutters / worm milling cutters pressure angle 20°, basic profile I DIN 3972, form A - with straight profile; form B with 10° inclined profile.

HSS (M2)

Módulo	d1 mm	B mm	C mm	d2 H6 mm
1	140	8	3	40
1,5	140	8	4	40
2	140	8	5	40
2,5	140	10	6,5	40
3	140	10	7,5	40
3,5	140	10	9	40
4	140	10	-	40
4,5	140	11	-	40
5	140	13	-	40
6	145	15	-	40
7	145	17	-	40
8	145	20	-	40
9	150	22	-	40
10	150	25	-	40



## 2521

dentes retos,  
detalonados  
straight teeth  
form relieved

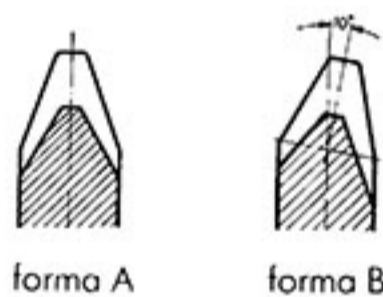

forma A

forma B

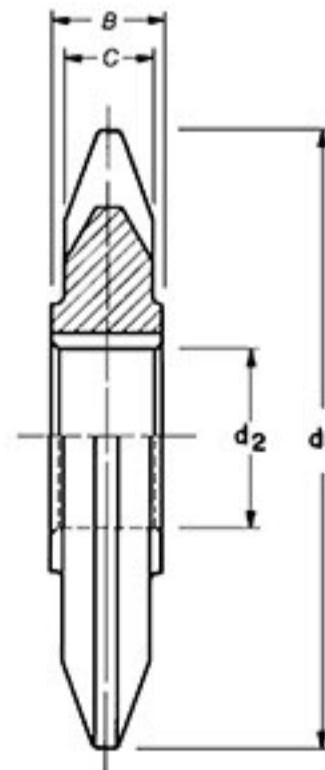

## 2522

dentes retos,  
retificados  
straight teeth  
ground form relieved