

Super Open Vice



MECHANICAL TYPE

EXCEPT THE HYDRAULIC SYSTEM,
THE FEATURE IS SAME AS VH-TYPE
ACCURACE WITHIN 0.02mm

VJ-400 JAW OPENED 185mm
VJ-500 JAW OPENED 245mm
VJ-600 JAW OPENED 305mm



VJ-600

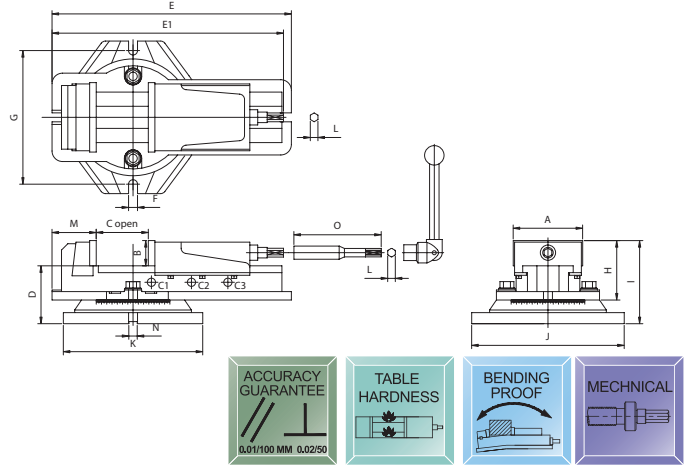

Order No. & Dimensions

ORDER NO.	A	B	C OPEN	Opening Size For Capacity			D	E	E1	F	G	H	I	J	K	L	M	N	O	Max. Clamp Force (kgf)	G.W. (kgs)	CFT (cm)	CODE NO.
				C1	C2	C3																	
VJ-400	110	38	185	0-65	52-129	116-185	97	386	516	15	240	96	135	270	238	14.5	90	16	156	1500	25	46x26x16	1002-050
VJ-500	132	48	245	0-78	70-158	150-245	110	455	580	17	255	113	158	290	265	14.5	85	16	166	1500	34	48x28x18	1002-051
VJ-600	154	56	305	0-111	97-211	197-305	118	546	722	17	255	131	175	290	265	19	111	16	200	1500	46	57x30x22	1002-052

2-Way Angle Milling Vice

MECHANICAL TYPE



VWT-4B

VWT-6B

- Tilting seat set by two locking screws, works in high stability.
- Angle setting ranges from 0°-15°. Tilting degrees graduated for easy reading. Swivel base graduated to 360° and fixable in any position.



SUPER OPEN CAPACITY:
VWT-4B JAW OPENED 220mm
VWT-6B JAW OPENED 350mm

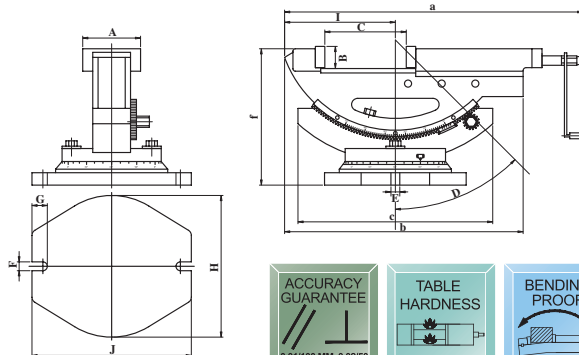

Order No. & Dimensions

ORDER NO.	A	B	C OPEN	D	E	F	G	H	I	J	a	b	c	f	Max. Clamp Force (kgf)	G.W. (kgs)	Meas CFT	CODE NO.
VWT-4B	110	36	220	50°	15	15	26	240	185	270	500	404	335	230	1200	(C) 33.3	1.2	1002-060B
VWT-6B	152	54	350	50°	20	19	28	300	246	330	800	585	415	290	1600	(W) 79.7	4.4	1002-061B